

ROVESCIAITORE DI CASSE RSI-111A

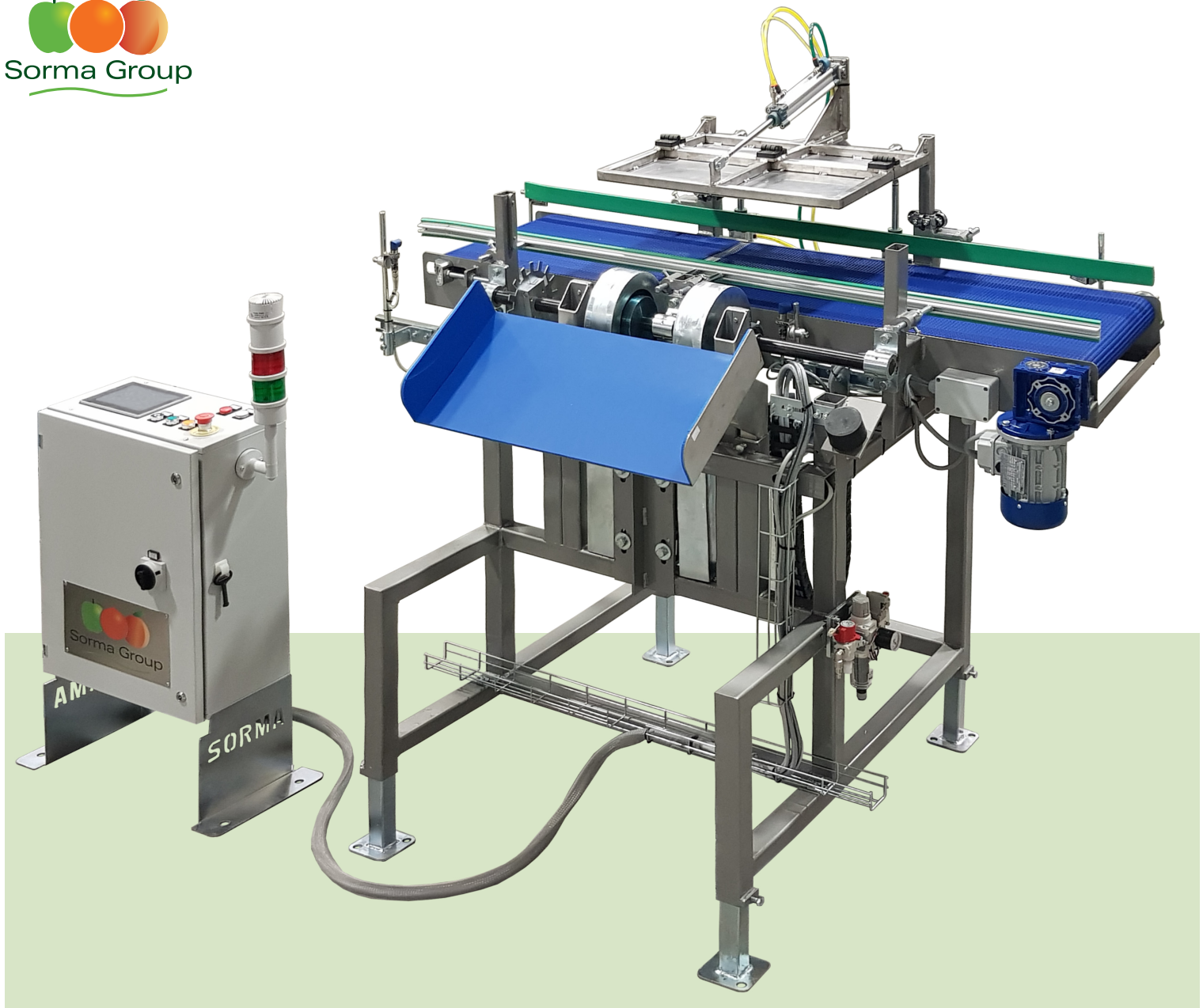

ROVESCIAITORE DI CASSE mod. RSI-111A

Rovesciatore automatico di casse adatto a rovesciare fino a 2 casse alla volta di frutta e verdura. Può lavorare diversi tipi di casse in plastica o legno.



BOX TIPPER mod. RSI-111A

Automatic box tipper suitable for overturning up to 2 boxes of fruit and vegetables at a time. It can process different types of plastic or wooden boxes.

DATI TECNICI/TECHNICAL DATA

PRODUZIONE
OUTPUT
PRODUCTION
LEISTUNG
PRODUCCIÓN

from 310 to 400 boxes / hour

POTENZA ELETTRICA INSTALLATA
INSTALLED POWER
PUISSANCE ELECTRIQUE INSTALLÉE
ANSCHLUSSWERT ELEKTR
POTENCIA ELÉCTRICA INSTALADA

1,5 kW • 50 Hz • 400 V

CONSUMO ARIA
AIR CONSUMPTION
CONSOMMATION D'AIR
LUFTVERBRAUCH
CONSUMO DE AIRE

10 NI/min • 6 bar

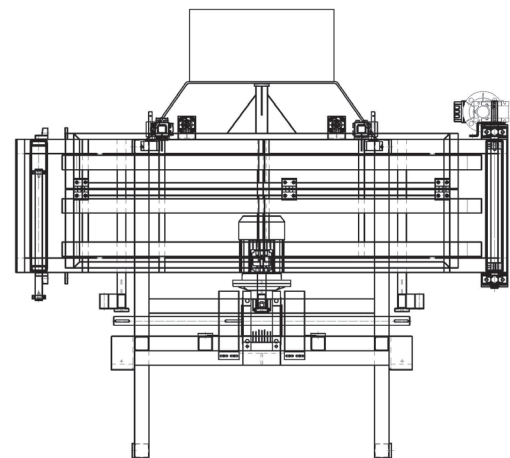
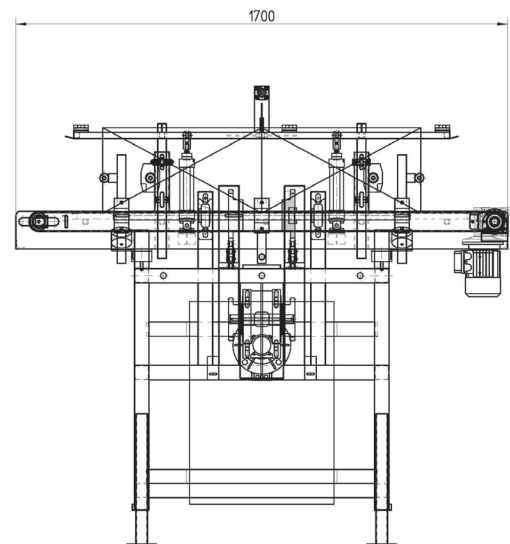
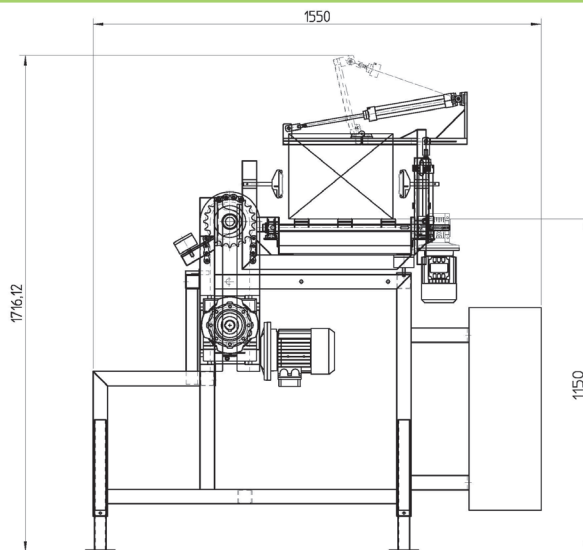

ROVESCIAIORE DI CASSE RSI-111A

AGENTE DI ZONA / LOCAL DEALER



SORMA S.p.A.

via Delle Mele, 65 - 47522 Cesena (FC) - ITALY

Tel. (+39) 0547 418611 - Fax. (+39) 0547 418612

sorma@sormaitalia.com - www.sormagroup.com