

ROBOT ANTROPOMORFO DRCA-180



ROBOT ANTROPOMORFO A 4 / 6 ASSI mod. DRCA-180

Il Robot antropomorfo a 4 / 6 assi è completo di pinza a contenitore e può essere adattato a diversi utilizzi. Nel caso raffigurato viene utilizzato per prelevare 6 casse piene, svuotarle su nastro trasportatore e reimpiare le casse vuote, oltre alla movimentazione dei pallet vuoti. In questa configurazione la produttività è di 900 - 950 casse /ora.

4 / 6 SHAFTS ANTHROPOMORPHIC ROBOT mod. DRCA-180

The 4 / 6 shafts anthropomorphic Robot is equipped with control pincers and can be adjusted to several conditions of use. In the drawn case, it is used to withdraw 6 full boxes, empty them on the belt conveyor and stack them in addition to the empty pallets movement. In this configuration the output is of 900 - 950 boxes / hour.

DATI TECNICI/TECHNICAL DATA

PRODUZIONE
OUTPUT
PRODUCTION
LEISTUNG
PRODUCCIÓN
Производство

900 - 950 casse / ora

POTENZA ELETTRICA INSTALLATA
INSTALLED POWER
PUISSANCE ELECTRIQUE INSTALLÉE
ANSCHLUSSWERT ELEKTR
POTENCIA ELÉCTRICA INSTALADA
Установленная мощность

15 kW • 50 Hz • 400 V

CONSUMO ARIA
AIR CONSUMPTION
CONSOMMATION D'AIR
LUFTVERBRAUCH
CONSUMO DE AIRE
Потребление воздуха

50 NI/min • 6 bar

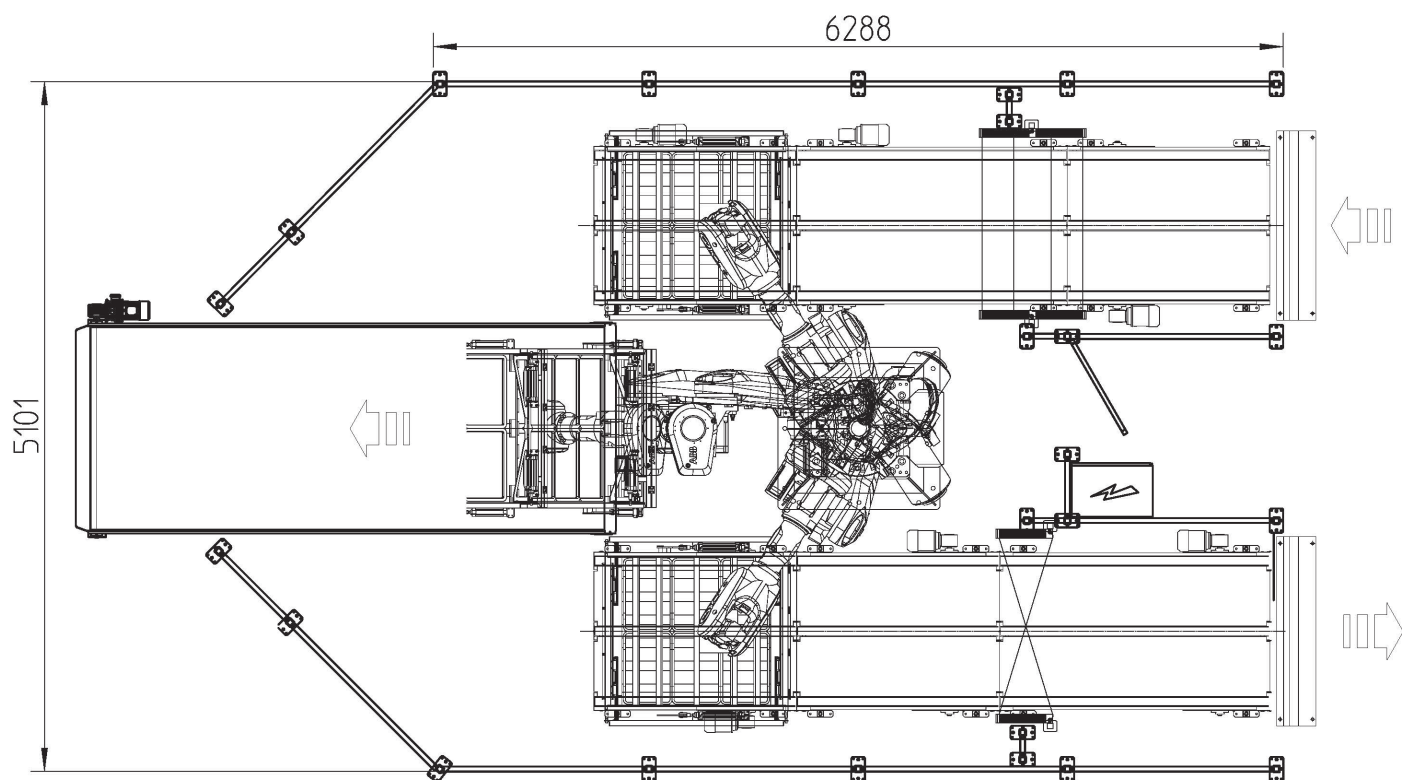

ROBOT ANTROPOMORFO DRCA-180

AGENTE DI ZONA / LOCAL DEALER



SORMA S.p.A.
via Delle Mele, 65 - 47522 Cesena (FC) - ITALY
Tel. (+39) 0547 418611 - Fax. (+39) 0547 418612
sorma@sormaitalia.com - www.sormagroup.com