

RIEMPITORE AUTOMATICO DI CESTINI ACE-115



RIEMPITORE AUTOMATICO DI CESTINI mod. ACE-115

La macchina è adatta a lavorare cestini da 0,5 a 1 kg di formato mm 112x195.

La macchina è costituita da:

- Telaio macchina e componenti in ferro verniciato,
- Sistema di guide-cestini regolabili manualmente,
- Quadro elettrico per il funzionamento in automatico.

La macchina è provvista di due tramogge in acciaio inox per riempire due cestini alla volta.

Optional:

- Lavorazione cestini da 500 g quadrati con corredo aggiuntivo di controtazze, Tempo necessario per il montaggio: 25÷30 minuti,
- Alimentatore automatico di cestini mod. DP4-115 o DP4-115X con telaio inox e provvisto di quadro proprio (4 magazzini - scambio automatico tra i due a comando pneumatico),
- Lavorazione cestini da 250 g con kit aggiuntivo di controtazze + legni di riduzione.



AUTOMATIC PUNNET FILLING MACHINE mod. ACE-115

The machine is suitable to handle 0,5 to 1 kg punnets, size 112x195.

The machine consists of:

- Structure in painted steel,
- Manually regulated punnet guide system,
- Complete with electrical control cabinet to control the automatic functions.

The machine includes two hoppers in stainless steel to fill 2 punnets in one movement.

Optional:

- KIT to handle 500 g square punnets with additional inserts, Time necessary to fit the kit: 25÷30 minutes,
- Automatic punnet denester mod. DP4-115 or DP4-115X manufactured in stainless steel complete with electrical control cabinet (4 rows),
- Kit to handle 250 g punnets with additional inserts and wooden reduction device.



REMPLEUSEUR AUTOMATIQUE DE BARQUETTES mod. ACE-115

La machine est indiquée pour travailler les barquettes de 0,5 à 1 kg avec des dimensions de 112x195mm.

La machine est composée par:

- Châssis de la machine en fer peint,
- Système de guide pour les barquettes réglables manuellement,
- Tableau électrique pour le fonctionnement automatique.

La machine est équipée de deux trémies en acier inox pour remplir deux barquettes à la fois.

Option:

- Kit pour travailler les barquettes carrées de 500 g avec des parties supplémentaires, Temps nécessaire pour l'assemblage du kit: 25÷30 minutes,
- Dépileur de barquettes mod. DP4-115 ou DP4-115X en acier inox et complet de tableau électrique (4 rangées),
- Kit pour travailler les barquettes de 250 g avec parties supplémentaires et système de réduction en bois.



DATI TECNICI/TECHNICAL DATA

PRODUZIONE
OUTPUT
PRODUCTION
LEISTUNG
PRODUCCIÓN

depending on the produce and
on the punnet to handle.
35 to 50 punnets/minute approx.

POTENZA ELETTRICA INSTALLATA
INSTALLED POWER
PUISSANCE ELECTRIQUE INSTALLÉE
ANSCHLUSSWERT ELEKTR
POTENCIA ELÉCTRICA INSTALADA

1,5 kW • 50 Hz • 400 V

CONSUMO ARIA
AIR CONSUMPTION
CONSOMMATION D'AIR
LUFTVERBRAUCH
CONSUMO DE AIRE

120 NI/min • 6 bar

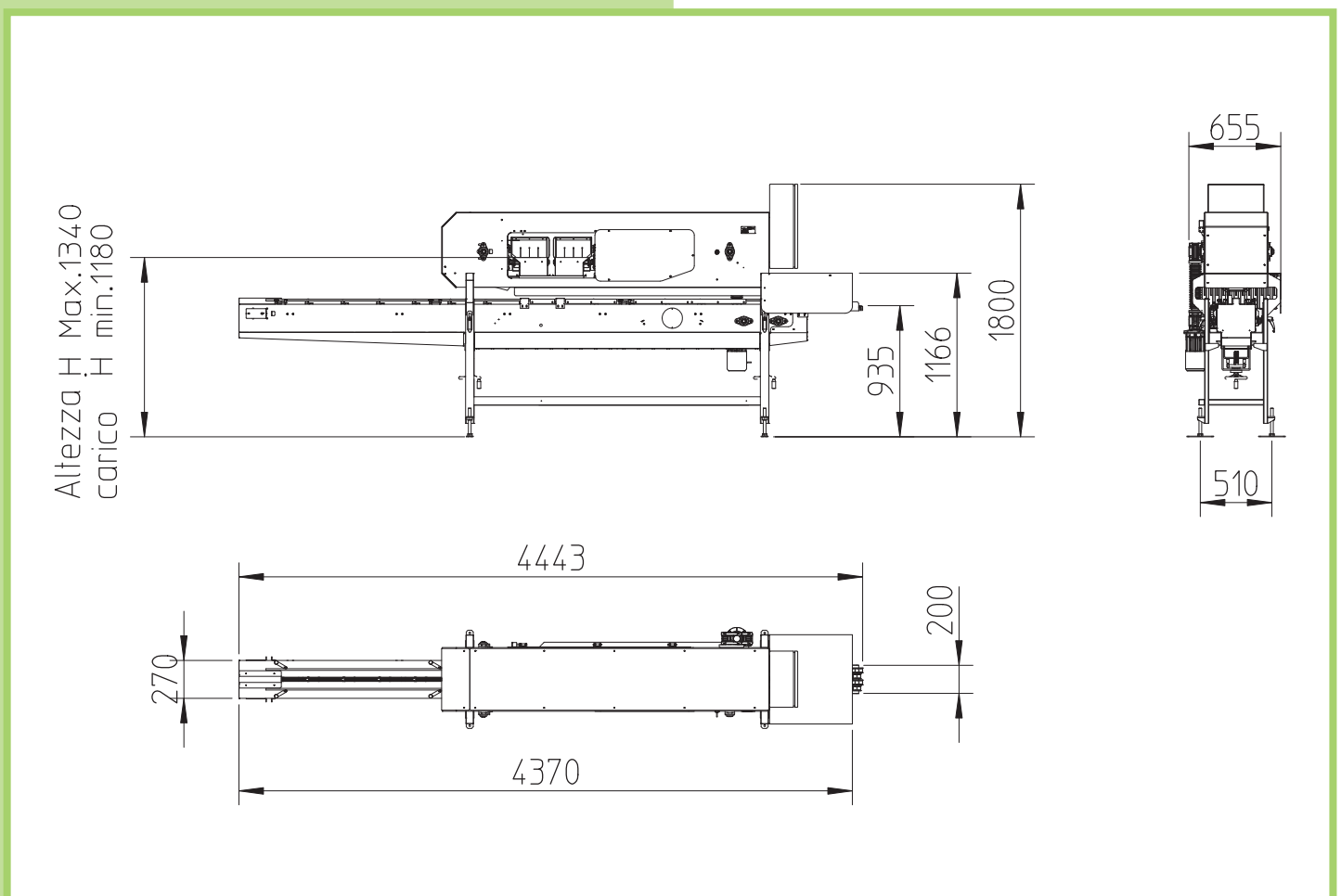

RIEMPITORE AUTOMATICO DI CESTINI ACE-115

AGENTE DI ZONA / LOCAL DEALER



SORMA S.p.A.

via Delle Mele, 65 - 47522 Cesena (FC) - ITALY

Tel. (+39) 0547 418611 - Fax. (+39) 0547 418612

sorma@sormaitalia.com - www.sormagroup.com